

Data Sheet

Product	Bluetooth Low Energy Module
Solution	Nordic nRF52840 aQFN Package
Model NO.	DK9177A (u.FL Connector)

Revision History

This table describes the changes to the specification.

Version	Date	Description
1.0.0	2024/05/28	Initial Version
1.0.1	2024/05/30	Add New Label
1.0.2	2024/05/31	Add Marking On Metal Shield
1.0.3	2024/05/31	Packaging Picture Correction

Index

1. Overall Introduction.....	5
1.1 Application.....	5
1.2 Product Specification.....	5
2. Product Dimension.....	7
2.1 PCB Dimensions & Pin Indication.....	7
2.2 Recommended Layout of Solder Pad.....	8
2.3 RF Layout Suggestion (aka KEEP-Out Area).....	9
2.4 Pin Assignment.....	10
3. Main Chip Solution.....	13
4. Shipment Packaging Information.....	13
4.1 Tape & Reel Packaging.....	14
4.2 Marking on Metal Shield.....	16
5. Specification.....	17
5.1 Absolute Maximum Ratings.....	17
5.2 Operating Conditions.....	18
5.3 Electrical Specifications.....	18
6. Block Diagram.....	24
7. Antenna.....	25
8. Reference Circuit.....	26
8.1 Reg0 DC/DC Enabled.....	27
8.2 Reg0 LDO Mode.....	29
8.3 Reg0 DC/DC and LDO Mode Disabled.....	31
8.4 USB Powered.....	33
8.5 USB Disabled.....	37

9. Notes and Cautions.....	38
10. Basic Facts for nRF52 Family.....	39
11. Useful Links.....	40
Full List of DEXATEK's BLE Modules.....	40

Dexatek Confidential

1. Overall Introduction

Dexatek's DK9177A is a BT 5 stack (Bluetooth low energy or BLE) module designed based on Nordic nRF52840 SoC solution, which incorporates: GPIO, SPI, UART, I2C, I2S, PMD, PWM, ADC, NFC and USB interfaces for connecting peripherals and sensors.

Ideal solution for designs requiring Bluetooth 5 functionality or 802.15.4-based Thread networking and Zigbee. Enhanced integration with built-in USB and 5.5 V compatible DC/DC power supplies reduces design complexity and BOM cost while expanding possible applications.

Provides ultra-low power consumption and excellent wireless range with +8 dBm transmission Power and long range (encoded physical layer) Bluetooth 5 capabilities. New circuits are added TX power and reduces sleep current for perfect power management.

1.1 Application

- Lighting products
- Home application
- Internet of things (IoT)
- Medical devices
- Factory automation
- IoT Sensors
- HVAC Controllers
- Industrial IoTsensors and Controllers
- Remote controls
- Smart Eenergy management
- Advanced Wearables
- Education entertainment devices
- Agriculture Application

1.2 Product Specification

- Bluetooth[®] 5.3 IEEE 802.15.4-2006, 2.4 GHz transceiver,
- LE 2M PHY, LE 1M PHY, LE Coded PHY (Long Range)
 - 2 Mbps, 1 Mbps, 500 kbps, and 125 kbps
 - IEEE 802.15.4-2006 – 250 kbps
 - Proprietary 2.4 GHz – 2 Mbps, 1 Mbps

- nRF52840, ARM[®] Cortex[®] M4 32-bit processor with FPU, 64 MHz
- 1 MB Flash and 256 kB RAM
- Radio
 - GFSK at 1 Mbps and 2 Mbps, QPSK at 250 Kbps
 - -95 dBm sensitivity in 1 Mbps Bluetooth[®] low energy mode -103 dBm sensitivity in 125 kbps Bluetooth[®] low energy mode (long range)
 - -20 to +8 dBm TX power, configurable in 4 dB steps
 - On-air compatible with nRF52, nRF51, nRF24L, and nRF24AP Serie
- Power Management
 - 1.7 V to 5.5 V supply voltage range
 - 1.8 V to 3.3 V regulated supply
- Security features
 - ARM[®] TrustZone[®] Cryptocell 310 security subsystem
 - 128-bit AES/ECB/CCM/AAR co-processor
- Peripheral interface / Hardware
 - USB 2.0 full speed (12 Mbps) controller
 - QSPI 32 MHz interface
 - High-speed 32 MHz SPI
 - Type 2 NFC-A tag with wake-on field
 - Touch-to-pair support
 - Programmable peripheral interconnect (PPI)
 - 48 general purpose I/O pins (GPIO)
 - EasyDMA automated data transfer between memory and peripherals
 - Nordic SoftDevice ready with support for concurrent multiprotocol
 - 12-bit, 200 ksps ADC – 8 configurable channels with programmable gain
 - 64 level comparator
 - 15 level low-power comparator with wake-up from System OFF mode
 - Temperature sensor
 - 4x4 channel PWM unit with EasyDMA
 - Audio peripherals – I2 S, digital microphone interface (PDM)
 - 5x 32-bit timer with counter mode
 - Up to 4x SPI master/3x SPI slave with EasyDMA
 - Up to 2x I2 C compatible two-wire master/slave
 - 2x UART (CTS/RTS) with EasyDMA
 - Quadrature decoder (QDEC)
 - 3x real-time counter (RTC)
- Operation Temperature: -40 °C to 85 °C

2. Product Dimension

2.1. PCB Dimensions & Pin Indication

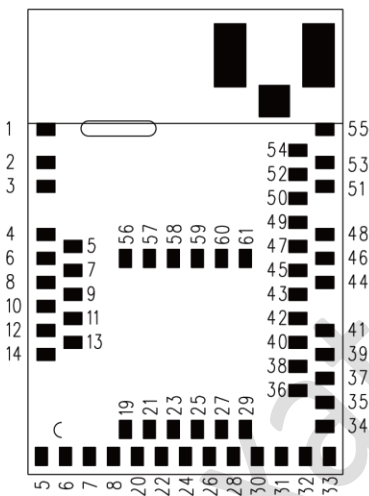
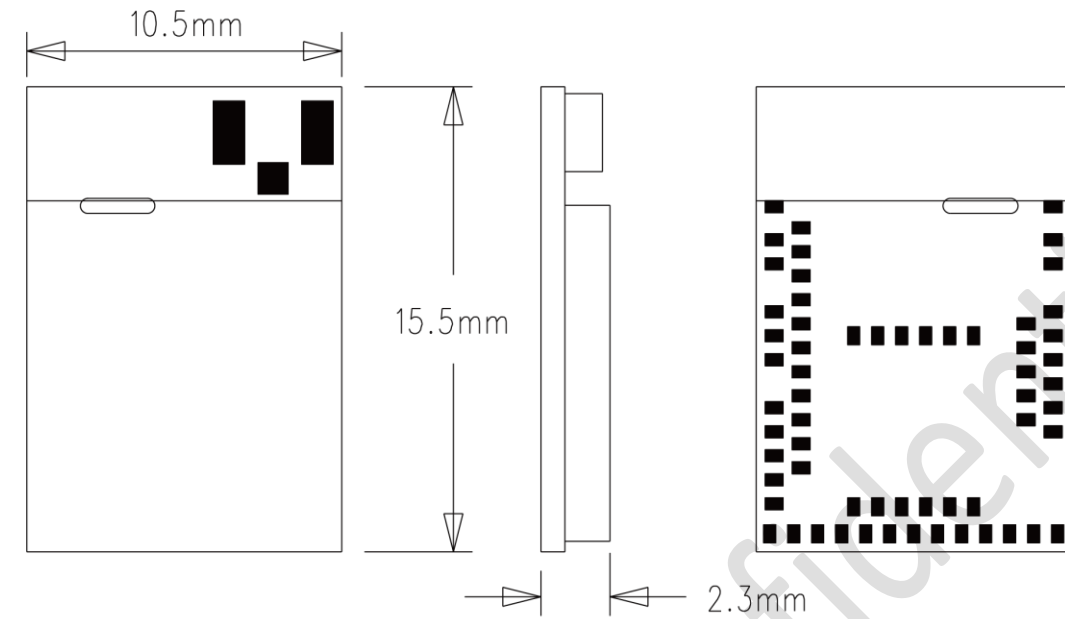

2.2. Recommended Layout of Solder Pad

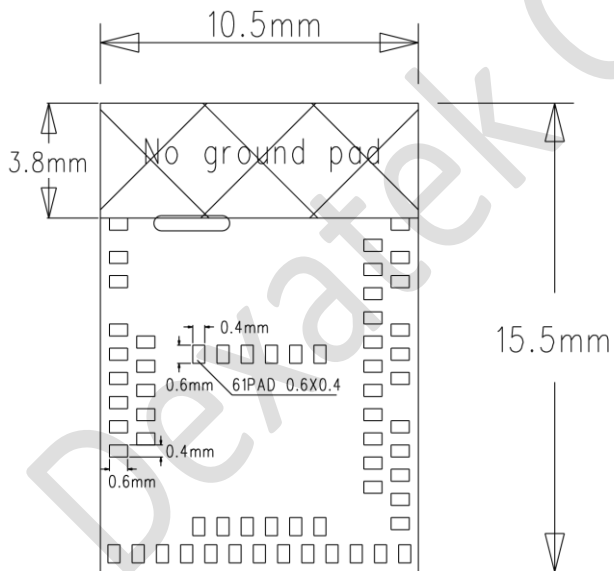
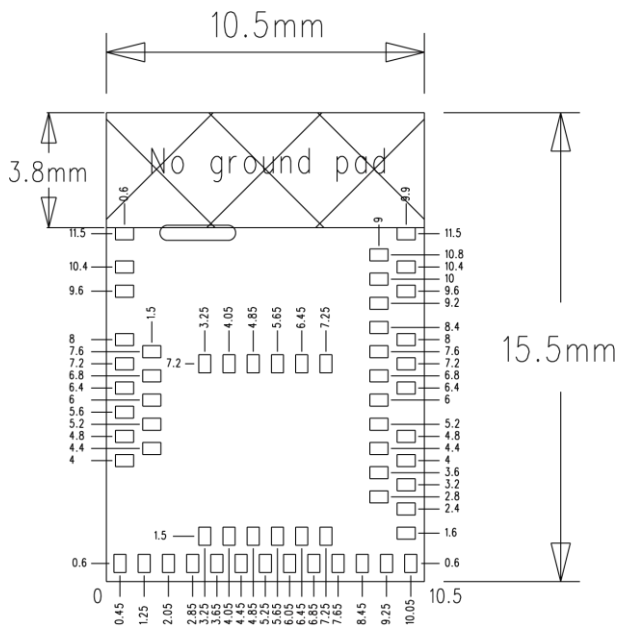

2.3. RF Layout Suggestion (aka Keep-Out Area)

Please follow below instruction to avoid from having Ground Pad in the area of our RF test pad. Otherwise, it may cause shortage to the module

 **No Ground-Pad Area**

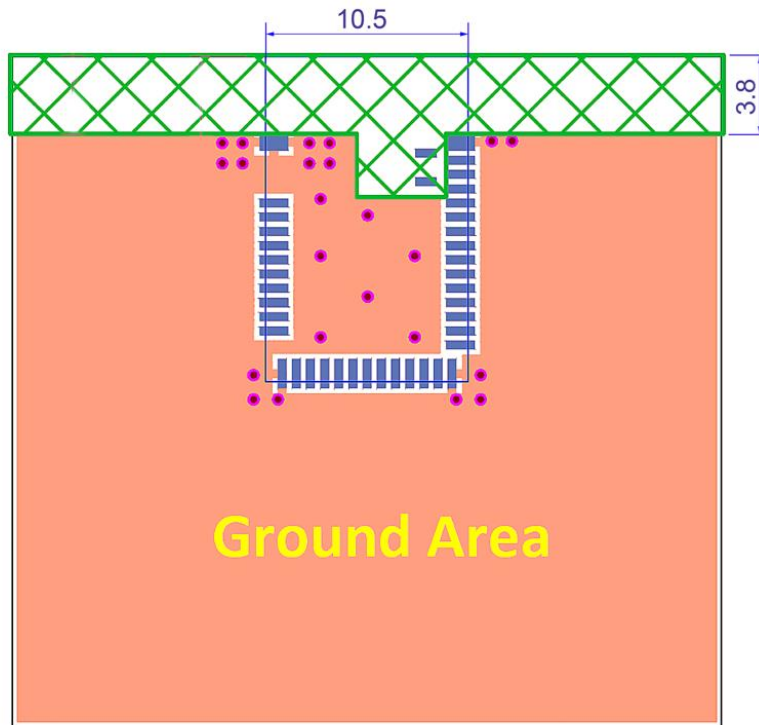

Top View

2.4 Pin Assignment

Pin	Name	Function	Description
1	GND	Power	Ground
2	GND	Power	Ground
3	P1.10	Digital I/O	General purpose I/O (standard drive, low frequency I/O only)
4	P1.11	Digital I/O	General purpose I/O General purpose I/O (standard drive, low frequency I/O only)
5	P1.12	Digital I/O	General purpose I/O General purpose I/O (standard drive, low frequency I/O only)
6	P1.13	Digital I/O	General purpose I/O General purpose I/O (standard drive, low frequency I/O only)
7	P1.14	Digital I/O	General purpose I/O General purpose I/O (standard drive, low frequency I/O only)
8	P1.15	Digital I/O	General purpose I/O General purpose I/O (standard drive, low frequency I/O only)
9	P0.03	Digital I/O	General purpose I/O General purpose I/O (standard drive, low frequency I/O only)
	AIN1	Analog input	Analog input
10	P0.29	Digital I/O	General purpose I/O General purpose I/O (standard drive, low frequency I/O only)
	AIN5	Analog input	Analog input
11	P0.02	Digital I/O	General purpose I/O General purpose I/O (standard drive, low frequency I/O only)
	AIN0	Analog input	Analog input
12	P0.31	Digital I/O	General purpose I/O General purpose I/O (standard drive, low frequency I/O only)
	AIN7	Analog input	Analog input
13	P0.28	Digital I/O	General purpose I/O General purpose I/O (standard drive, low frequency I/O only)
	AIN4	Analog input	Analog input
14	P0.30	Digital I/O	General purpose I/O General purpose I/O (standard drive, low frequency I/O only)
	AIN6	Analog input	Analog input
15	GND	Power	Ground
16	P0.27	Digital I/O	General purpose I/O General purpose I/O

17	P0.00	Digital I/O	General purpose I/O
	XL1	Analog input	Connection for 32.768 kHz crystal
18	P0.01	Digital I/O	General purpose I/O
	XL2	Analog input	Connection for 32.768 kHz crystal
19	P0.26	Digital I/O	General purpose I/O
20	P0.04	Digital I/O	General purpose I/O
	AIN2	Analog input	Analog input
21	P0.05	Digital I/O	General purpose I/O
	AIN3	Analog input	Analog input
22	P0.06	Digital I/O	General purpose I/O
23	P0.07	Digital I/O	General purpose I/O
	TRACECLK	Trace clock	Trace buffer clock
24	P0.08	Digital I/O	General purpose I/O
25	P1.08	Digital I/O	General purpose I/O
26	P1.09	Digital I/O	General purpose I/O
	TRACEDATA(3)	Trace data	Trace buffer TRACEDATA [3].
27	P0.11	Digital I/O	General purpose I/O
	TRACEDATA(2)	Trace data	Trace buffer TRACEDATA [2].
28	VDD	Power	Power supply
29	P0.12	General purpose I/O	General purpose I/O
	TRACEDATA(1)	Trace data	Trace buffer TRACEDATA [1].
30	VDDH	Power	High voltage power supply
31	DCCH	Power	DC/DC converter output
32	VBUS	Power	5V input for USB 3.3V regulator
33	GND	Power	Ground
34	D-	Digital I/O	USB D-
35	D+	Digital I/O	USB D+
36	P0.14	Digital I/O	General purpose I/O
37	P0.13	Digital I/O	General purpose I/O
38	P0.16	Digital I/O	General purpose I/O

39	P0.15	Digital I/O	General purpose I/O General purpose I/O
40	P0.18	Digital I/O	General purpose I/O General purpose I/O (recommended usage: QSPI / CSN))
	nRESET		Configurable as system reset
41	P0.17	Digital I/O	General purpose I/O General purpose I/O
42	P0.19	Digital I/O	General purpose I/O General purpose I/O (recommended usage: (QSPI / SCK))
43	P0.21	Digital I/O	General purpose I/O General purpose I/O (recommended usage: QSPI)
44	P0.20	Digital I/O	General purpose I/O General purpose I/O
45	P0.23	Digital I/O	General purpose I/O General purpose I/O (recommended usage: QSPI)
46	P0.22	Digital I/O	General purpose I/O General purpose I/O (recommended usage: QSPI)
47	P1.00	Digital I/O	General purpose I/O General purpose I/O (recommended usage: QSPI)
	TRACEDATA(0)	Trace data	Trace buffer TRACEDATA [0].
48	P0.24	Digital I/O	General purpose I/O General purpose I/O
49	P0.25	Digital I/O	General purpose I/O General purpose I/O
50	P1.02	Digital I/O	General purpose I/O General purpose I/O (standard drive, low frequency I/O only)
51	SWDIO	Debug	Serial wire debug I/O for debug and programming
52	P0.09	Digital I/O	General purpose I/O General purpose I/O (standard drive, low frequency I/O only)
	NFC1	NFC input	NFC antenna connection
53	SWDCLK	Debug	Serial wire debug clock input for debug and programming
54	P0.10	Digital I/O	General purpose I/O General purpose I/O (standard drive, low frequency I/O only)
	NFC2	NFC input	NFC antenna connection
55	GND	Power	Ground
56	P1.04	Digital I/O	General purpose I/O General purpose I/O (standard drive, low frequency I/O only)
57	P1.06	Digital I/O	General purpose I/O General purpose I/O (standard drive, low frequency I/O only)
58	P1.07	Digital I/O	General purpose I/O General purpose I/O (standard drive, low frequency I/O only)
59	P1.05	Digital I/O	General purpose I/O General purpose I/O (standard drive, low frequency I/O only)
60	P1.03	Digital I/O	General purpose I/O General purpose I/O (standard drive, low frequency I/O only)
61	P1.01	Digital I/O	General purpose I/O General purpose I/O (standard drive, low frequency I/O only)

3. Main Chip Solution

RF IC	Crystal Frequency
Nordic NRF52840	32MHZ

32MHz crystal and RF (VDD) DC/DC inductor (Reg1) are already inside the module.

4. Shipment Packaging Information

Model	Antenna	Photo
DK9177A	u.FL Connector	

※Unit Weight of Module: 0.68g (±0.02g)

※Packaging Type: Anti-static tray or Tape & Reel

	Tape & Reel
MPQ (Min. Package Qty)	600 pcs per reel
Carton Contents (per Carton)	600 pcs
Carton Dimension L*W*H cm	37*36*6
Gross Weight	About 1.9kgs

4.1. Tape & Reel Packaging

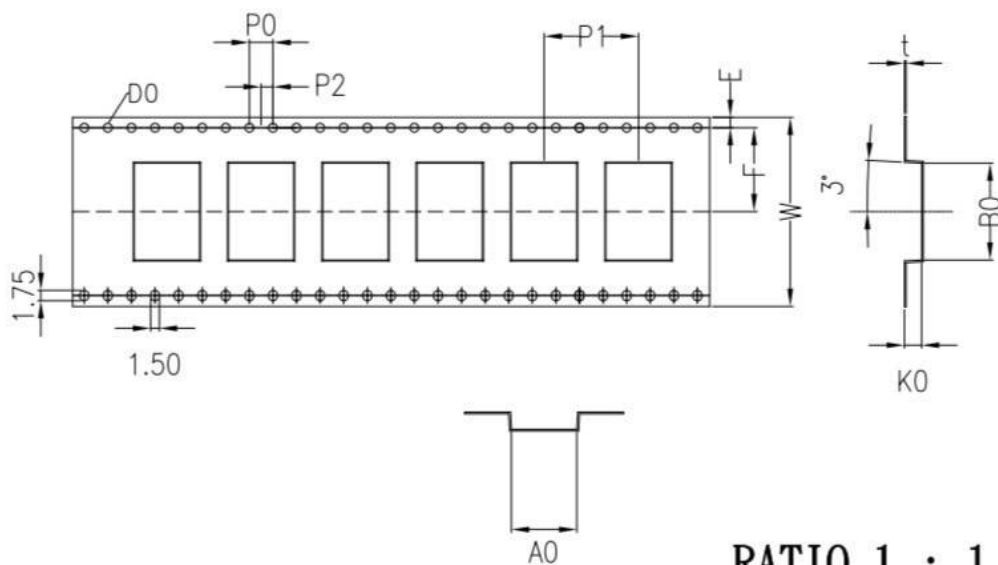
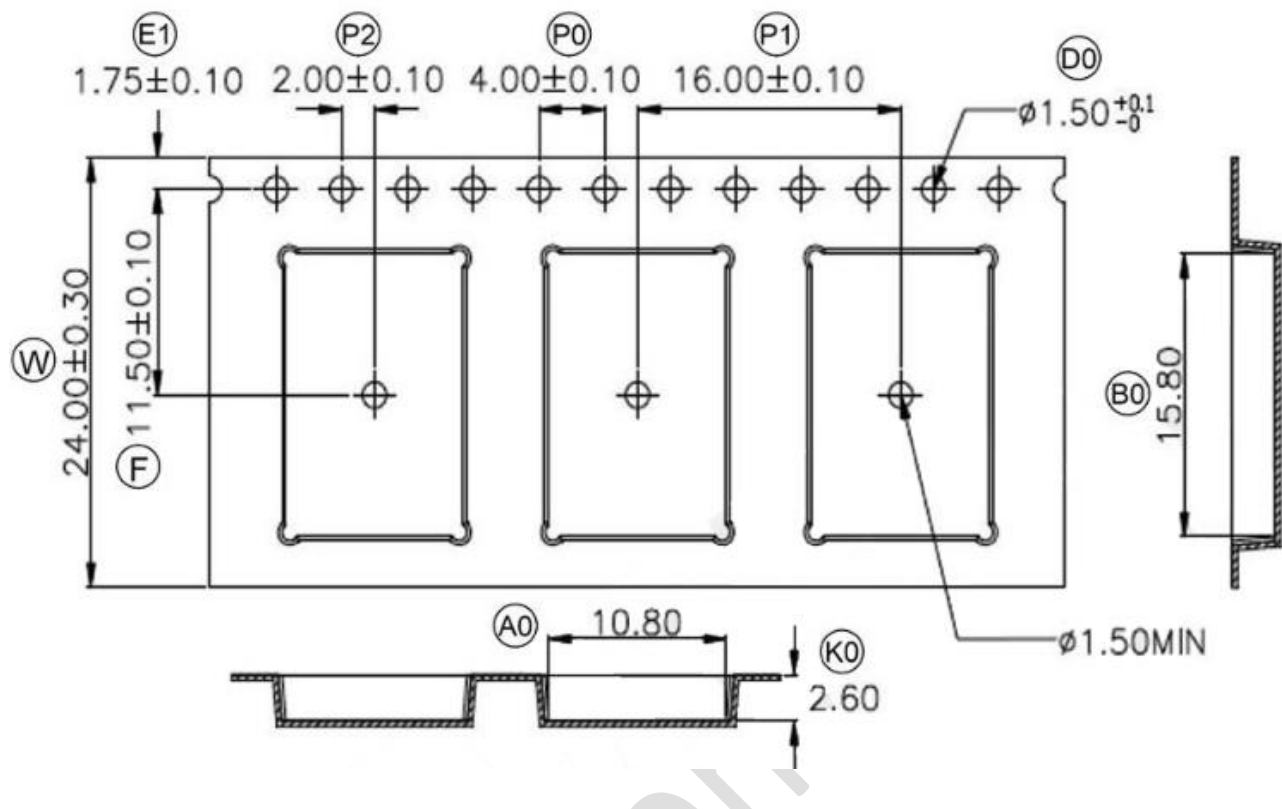

ITEM	SPEC
W	32.00 ^{+0.30} / _{-0.30}
Ao	11.10 ^{+0.10} / _{-0.10}
Bo	16.40 ^{+0.10} / _{-0.10}
Ko	2.90 ^{+0.10} / _{-0.10}
P1	16.00 ^{+0.10} / _{-0.10}
F	14.20 ^{+0.15} / _{-0.15}
E	1.75 ^{+0.10} / _{-0.10}
D0	1.50 ^{+0.10} / _{-0.00}
D1	0.00 ^{+0.10} / _{-0.00}
Po	4.00 ^{+0.10} / _{-0.10}
P2	2.00 ^{+0.15} / _{-0.15}
t	0.40 ^{+0.05} / _{-0.05}

DEXATEK

DEVICE: DK91xxA



QTY : 600



D / C: 24xx



MSL1

Part Number	DK91xxA
Quantity	600 pcs
Date Code	24xx

4.2. Marking on Metal Shield

4.2.1. Label

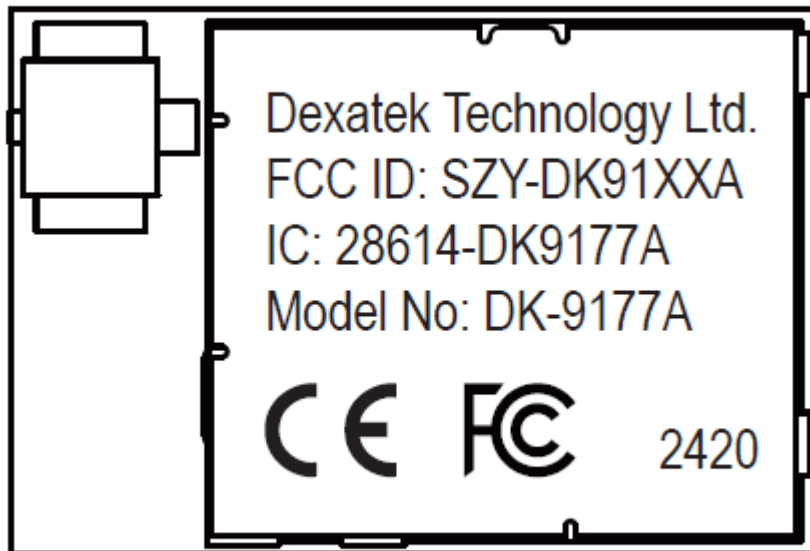

Dexatek Co., Ltd.

5. Specification

Any technical spec shall refer to Nordic's official documents as final reference.

5.1. Absolute Maximum Ratings

	Note	Min.	Max.	Unit
Supply voltages				
VDD		-0.3	+3.9	V
VDDH		-0.3	+5.8	V
VBUS		-0.3	+5.8	V
VSS			0	V
I/O pin voltage				
$V_{I/O}$, VDD \leq 3.6 V		-0.3	VDD + 0.3	V
$V_{I/O}$, VDD > 3.6 V		-0.3	3.9	V
NFC antenna pin current				
$I_{NFC1/2}$			80	mA
Radio				
RF input level			10	dBm
Environmental aQFN™ 73 package				
Storage temperature		-40	+125	°C
MSL	Moisture Sensitivity Level		2	
ESD HBM	Human Body Model		2	kV
ESD HBM Class	Human Body Model Class		2	
ESD CDM	Charged Device Model		450	V
Environmental QFN48 package				
Storage temperature		-40	+125	°C
MSL	Moisture Sensitivity Level		2	
ESD HBM	Human Body Model		4	kV
ESD HBM Class	Human Body Model Class		3A	
ESD CDM	Charged Device Model		1	kV
Environmental WLCSP 3.544 x 3.607 mm package				
Storage temperature		-40	+125	°C
MSL	Moisture Sensitivity Level		1	
ESD HBM	Human Body Model		1	kV
ESD HBM Class	Human Body Model Class		1C	
ESD CDM	Charged Device Model		500	V
Flash memory				
Endurance		10 000		write/erase cycles
Retention at 85 °C		10		years

5.2. Operating Conditions

Symbol	Description	Min.	Typ.	Max.	Units
V _{DD,POR}	VDD supply voltage needed during power-on reset	1.75			V
V _{DD}	Normal voltage mode operating voltage	1.7	3.0	3.6	V
V _{DDH}	High voltage mode operating voltage	2.5	3.7	5.5	V
C _{VDD}	Effective decoupling capacitance on the VDD pin	2.7	4.7	5.5	μF
C _{DEC4}	Effective decoupling capacitance on the DEC4 pin	0.7	1	1.3	μF

5.3. Electrical Specifications

5.3.1. General Radio Characteristics

Symbol	Description	Min.	Typ.	Max.	Units
f _{OP}	Operating frequencies	2360		2500	MHz
f _{PLL,CH,SP}	PLL channel spacing		1		MHz
f _{DELTA,1M}	Frequency deviation @ 1 Mbps		±170		kHz
f _{DELTA,BLE,1M}	Frequency deviation @ BLE 1 Mbps		±250		kHz
f _{DELTA,2M}	Frequency deviation @ 2 Mbps		±320		kHz
f _{DELTA,BLE,2M}	Frequency deviation @ BLE 2 Mbps		±500		kHz
f _{skBPS}	On-the-air data rate	125		2000	kbps
f _{chip, IEEE 802.15.4}	Chip rate in IEEE 802.15.4 mode		2000		kchip, s

5.3.2. Radio Current Consumption (Transmitter)

Symbol	Description	Min.	Typ.	Max.	Units
I _{TX,PLUS8dBm,DCDC}	TX only run current (DC/DC, 3 V) P _{RF} = +8 dBm		14.8		mA
I _{TX,PLUS8dBm}	TX only run current P _{RF} = +8 dBm		32.7		mA
I _{TX,PLUS4dBm,DCDC}	TX only run current (DC/DC, 3 V) P _{RF} = +4 dBm		9.6		mA
I _{TX,PLUS4dBm}	TX only run current P _{RF} = +4 dBm		21.4		mA
I _{TX,0dBm,DCDC,5V,REG0HIGH}	TX only run current (DC/DC, 5 V, REG0 out = 3.3 V) P _{RF} = 0 dBm		3.0		mA
I _{TX,0dBm,DCDC,5V,REG0LOW}	TX only run current (DC/DC, 5 V, REG0 out = 1.8 V) P _{RF} = 0 dBm		3.0		mA
I _{TX,0dBm,DCDC}	TX only run current (DC/DC, 3 V) P _{RF} = 0 dBm		4.8		mA
I _{TX,0dBm}	TX only run current P _{RF} = 0 dBm		10.6		mA
I _{TX,MINUS4dBm,DCDC}	TX only run current DC/DC, 3 V P _{RF} = -4 dBm		3.1		mA
I _{TX,MINUS4dBm}	TX only run current P _{RF} = -4 dBm		8.1		mA
I _{TX,MINUS8dBm,DCDC}	TX only run current DC/DC, 3 V P _{RF} = -8 dBm		3.3		mA
I _{TX,MINUS8dBm}	TX only run current P _{RF} = -8 dBm		7.2		mA
I _{TX,MINUS12dBm,DCDC}	TX only run current DC/DC, 3 V P _{RF} = -12 dBm		3.0		mA
I _{TX,MINUS12dBm}	TX only run current P _{RF} = -12 dBm		6.4		mA
I _{TX,MINUS16dBm,DCDC}	TX only run current DC/DC, 3 V P _{RF} = -16 dBm		2.8		mA
I _{TX,MINUS16dBm}	TX only run current P _{RF} = -16 dBm		6.0		mA
I _{TX,MINUS20dBm,DCDC}	TX only run current DC/DC, 3 V P _{RF} = -20 dBm		2.7		mA
I _{TX,MINUS20dBm}	TX only run current P _{RF} = -20 dBm		5.6		mA
I _{TX,MINUS40dBm,DCDC}	TX only run current DC/DC, 3 V P _{RF} = -40 dBm		2.3		mA
I _{TX,MINUS40dBm}	TX only run current P _{RF} = -40 dBm		4.6		mA
I _{START,TX,DCDC}	TX start-up current DC/DC, 3 V, P _{RF} = 4 dBm		5.2		mA
I _{START,TX}	TX start-up current, P _{RF} = 4 dBm		11.0		mA

5.3.3. Radio Current Consumption (Receiver)

Symbol	Description	Min.	Typ.	Max.	Units
I _{RX,1M,DCDC}	RX only run current (DC/DC, 3 V) 1 Mbps/1 Mbps BLE		4.6		mA
I _{RX,1M}	RX only run current (LDO, 3 V) 1 Mbps/1 Mbps BLE		9.9		mA
I _{RX,2M,DCDC}	RX only run current (DC/DC, 3 V) 2 Mbps/2 Mbps BLE		5.2		mA
I _{RX,2M}	RX only run current (LDO, 3 V) 2 Mbps/2 Mbps BLE		11.1		mA
I _{START,RX,1M,DCDC}	RX start-up current (DC/DC, 3 V) 1 Mbps/1 Mbps BLE		3.7		mA
I _{START,RX,1M}	RX start-up current 1 Mbps/1 Mbps BLE		6.7		mA

5.3.4. Transmitter Specification

Symbol	Description	Min.	Typ.	Max.	Units
P _{RF}	Maximum output power		8.0		dBm
P _{RFC}	RF power control range		28.0		dB
P _{RFCR}	RF power accuracy			±4	dB
P _{RF1,1}	1st Adjacent Channel Transmit Power 1 MHz (1 Mbps)		-24.8		dBc
P _{RF2,1}	2nd Adjacent Channel Transmit Power 2 MHz (1 Mbps)		-54.0		dBc
P _{RF1,2}	1st Adjacent Channel Transmit Power 2 MHz (2 Mbps)		-25		dBc
P _{RF2,2}	2nd Adjacent Channel Transmit Power 4 MHz (2 Mbps)		-54.0		dBc
E _{vm}	Error vector magnitude IEEE 802.15.4		8		%rms
P _{harm2nd, IEEE 802.15.4}	2nd harmonics in IEEE 802.15.4 mode		-51.0		dBm
P _{harm3rd, IEEE 802.15.4}	3rd harmonics in IEEE 802.15.4		-48.0		dBm

5.3.5. RSSI Specification

Symbol	Description	Min.	Typ.	Max.	Units
RSSI _{ACC}	RSSI accuracy valid range -90 to -20 dBm		±2		dB
RSSI _{RESOLUTION}	RSSI resolution		1		dB
RSSI _{PERIOD}	RSSI sampling time from RSSI_START task		0.25		μs
RSSI _{SETTLE}	RSSI settling time after signal level change		15		μs

5.3.6. Receiver Operation

Symbol	Description	Min.	Typ.	Max.	Units
P _{RX,MAX}	Maximum received signal strength at < 0.1% PER		0		dBm
P _{SENS,IT,1M}	Sensitivity, 1 Mbps nRF mode ideal transmitter ¹⁹		-93		dBm
P _{SENS,IT,2M}	Sensitivity, 2 Mbps nRF mode ideal transmitter ²⁰		-89		dBm
P _{SENS,IT,SP,1M,BLE}	Sensitivity, 1 Mbps BLE ideal transmitter, packet length ≤ 37 bytes BER=1E-3 ²¹		-95		dBm
P _{SENS,IT,LP,1M,BLE}	Sensitivity, 1 Mbps BLE ideal transmitter, packet length ≥ 128 bytes BER=1E-4 ²²		-94		dBm
P _{SENS,IT,SP,2M,BLE}	Sensitivity, 2 Mbps BLE ideal transmitter, packet length ≤ 37 bytes		-92		dBm
P _{SENS,IT,BLE LE125k}	Sensitivity, 125 kbps BLE mode		-103		dBm
P _{SENS,IT,BLE LE500k}	Sensitivity, 500 kbps BLE mode		-99		dBm
P _{SENS,IEEE 802.15.4}	Sensitivity in IEEE 802.15.4 mode		-100		dBm

5.3.7. RX Selectivity

Symbol	Description	Typ.	Units
C/I _{1M,co-channel}	1Mbps mode, Co-Channel interference	9	dB
C/I _{1M,-1MHz}	1 Mbps mode, Adjacent (-1 MHz) interference	-2	dB
C/I _{1M,+1MHz}	1 Mbps mode, Adjacent (+1 MHz) interference	-10	dB
C/I _{1M,-2MHz}	1 Mbps mode, Adjacent (-2 MHz) interference	-19	dB
C/I _{1M,+2MHz}	1 Mbps mode, Adjacent (+2 MHz) interference	-42	dB
C/I _{1M,-3MHz}	1 Mbps mode, Adjacent (-3 MHz) interference	-38	dB
C/I _{1M,+3MHz}	1 Mbps mode, Adjacent (+3 MHz) interference	-48	dB
C/I _{1M,±6MHz}	1 Mbps mode, Adjacent (≥6 MHz) interference	-50	dB
C/I _{1MBLE,co-channel}	1 Mbps BLE mode, Co-Channel interference	6	dB
C/I _{1MBLE,-1MHz}	1 Mbps BLE mode, Adjacent (-1 MHz) interference	-2	dB
C/I _{1MBLE,+1MHz}	1 Mbps BLE mode, Adjacent (+1 MHz) interference	-9	dB
C/I _{1MBLE,-2MHz}	1 Mbps BLE mode, Adjacent (-2 MHz) interference	-22	dB
C/I _{1MBLE,+2MHz}	1 Mbps BLE mode, Adjacent (+2 MHz) interference	-46	dB
C/I _{1MBLE,>3MHz}	1 Mbps BLE mode, Adjacent (≥3 MHz) interference	-50	dB
C/I _{1MBLE,image}	Image frequency interference	-22	dB
C/I _{1MBLE,image,1MHz}	Adjacent (1 MHz) interference to in-band image frequency	-35	dB
C/I _{2M,co-channel}	2 Mbps mode, Co-Channel interference	10	dB
C/I _{2M,-2MHz}	2 Mbps mode, Adjacent (-2 MHz) interference	6	dB
C/I _{2M,+2MHz}	2 Mbps mode, Adjacent (+2 MHz) interference	-19	dB
C/I _{2M,-4MHz}	2 Mbps mode, Adjacent (-4 MHz) interference	-20	dB
C/I _{2M,+4MHz}	2 Mbps mode, Adjacent (+4 MHz) interference	-44	dB

5.3.8. RX Intermodulation

Symbol	Description	Min.	Typ.	Max.	Units
P _{IMD,5TH,1M}	IMD performance, 1 Mbps, 5th offset channel, packet length ≤ 37 bytes		-33		dBm
P _{IMD,5TH,1M,BLE}	IMD performance, BLE 1 Mbps, 5th offset channel, packet length ≤ 37 bytes		-30		dBm
P _{IMD,5TH,2M}	IMD performance, 2 Mbps, 5th offset channel, packet length ≤ 37 bytes		-33		dBm
P _{IMD,5TH,2M,BLE}	IMD performance, BLE 2 Mbps, 5th offset channel, packet		-31		dBm

5.3.9. Radio Timing

Symbol	Description	Min.	Typ.	Max.	Units
t _{TXEN,BLE,1M}	Time between TXEN task and READY event after channel FREQUENCY configured (1 Mbps BLE and 150 μs TIFS)	140		140	μs
t _{TXEN,FAST,BLE,1M}	Time between TXEN task and READY event after channel FREQUENCY configured (1 Mbps BLE with fast ramp-up and 150 μs TIFS)	40		40	μs
t _{TXDIS,BLE,1M}	When in TX, delay between DISABLE task and DISABLED event for MODE = Nrf_1Mbit and MODE = Ble_1Mbit	6		6	μs
t _{RXEN,BLE,1M}	Time between the RXEN task and READY event after channel FREQUENCY configured (1 Mbps BLE)	140		140	μs
t _{RXEN,FAST,BLE,1M}	Time between the RXEN task and READY event after channel FREQUENCY configured (1 Mbps BLE with fast ramp-up)	40		40	μs
t _{RXDIS,BLE,1M}	When in RX, delay between DISABLE task and DISABLED event for MODE = Nrf_1Mbit and MODE = Ble_1Mbit	0		0	μs
t _{TXDIS,BLE,2M}	When in TX, delay between DISABLE task and DISABLED event for MODE = Nrf_2Mbit and MODE = Ble_2Mbit	4		4	μs
t _{RXDIS,BLE,2M}	When in RX, delay between DISABLE task and DISABLED event for MODE = Nrf_2Mbit and MODE = Ble_2Mbit	0		0	μs
t _{TXEN,IEEE 802.15.4}	Time between TXEN task and READY event after channel FREQUENCY configured (IEEE 802.15.4)	130		130	μs
t _{TXEN,FAST,IEEE 802.15.4}	Time between TXEN task and READY event after channel FREQUENCY configured (IEEE 802.15.4 with fast ramp-up)	40		40	μs
t _{TXDIS,IEEE 802.15.4}	When in TX, delay between DISABLE task and DISABLED event (IEEE 802.15.4)	21		21	μs
t _{RXEN,IEEE 802.15.4}	Time between the RXEN task and READY event after channel FREQUENCY configured (IEEE 802.15.4)	130		130	μs
t _{RXEN,FAST,IEEE 802.15.4}	Time between the RXEN task and READY event after channel FREQUENCY configured (IEEE 802.15.4 with fast ramp-up)	40		40	μs
t _{RXDIS,IEEE 802.15.4}	When in RX, delay between DISABLE task and DISABLED event (IEEE 802.15.4)	0.5		0.5	μs
t _{RX-to-TX turnaround}	Maximum TX-to-RX or RX-to-TX turnaround time in IEEE 802.15.4 mode		40		μs

5.3.10. CPU



Symbol	Description	Typ.	
I _{CPU0}	CPU running CoreMark @64 MHz from flash, Clock = HFXO, Regulator = DC/DC	3.3	mA
I _{CPU1}	CPU running CoreMark @64 MHz from flash, Clock = HFXO	6.3	mA
I _{CPU2}	CPU running CoreMark @64 MHz from RAM, Clock = HFXO, Regulator = DC/DC	2.8	mA
I _{CPU3}	CPU running CoreMark @64 MHz from RAM, Clock = HFXO	5.2	mA
I _{CPU4}	CPU running CoreMark @64 MHz from flash, Clock = HFINT, Regulator = DC/DC	3.1	mA

5.3.11. Power Management

Symbol	Description	Min.	Typ.	Max.	Units
I _{ON_RAMOFF_EVENT}	System ON, no RAM retention, wake on any event		0.97		μA
I _{ON_RAMON_EVENT}	System ON, full 256 kB RAM retention, wake on any event		2.35		μA
I _{ON_RAMON_POF}	System ON, full 256 kB RAM retention, wake on any event, power-fail comparator enabled		2.35		μA
I _{ON_RAMON_GPIOTE}	System ON, full 256 kB RAM retention, wake on GPIOTE input (event mode)		17.37		μA
I _{ON_RAMON_GPIOTEPORT}	System ON, full 256 kB RAM retention, wake on GPIOTE PORT event		2.36		μA
I _{ON_RAMOFF_RTC}	System ON, no RAM retention, wake on RTC (running from LFRC clock)		1.50		μA
I _{ON_RAMON_RTC}	System ON, full 256 kB RAM retention, wake on RTC (running from LFRC clock)		3.16		μA
I _{OFF_RAMOFF_RESET}	System OFF, no RAM retention, wake on reset		0.40		μA
I _{OFF_RAMOFF_LPCOMP}	System OFF, no RAM retention, wake on LPCOMP		0.86		μA
I _{OFF_RAMON_RESET}	System OFF, full 256 kB RAM retention, wake on reset		1.86		μA
I _{ON_RAMOFF_EVENT_5V}	System ON, no RAM retention, wake on any event, 5 V supply on VDDH, REG0 output = 3.3 V		1.29		μA
I _{OFF_RAMOFF_RESET_5V}	System OFF, no RAM retention, wake on reset, 5 V supply on VDDH, REG0 output = 3.3 V		0.95		μA

7. Antenna

Below chart shows a few options of external antenna which has been tested and approved to use with DK9177A

#	Photo	Model No.	Type	Supplier	Gain	Certification
1		ANTX100 ETHAB24553	External	Yageo	≤ 2 dBi	FCC, IC, NCC, CE
2		ANTX100 P011B24003	PCB	Yageo	2.2 dBi	FCC, IC, NCC, CE
3		ANTX100 P111B24003	PCB	Yageo	3.3 dBi	FCC, IC, NCC, CE

8. Reference Circuit

This is a notification for circuit combinations and please refer below caution for specification, and carefully in detail description as applies to adapt on peripherals circuits.

- The Modules pre-programmed Dexatek test code inside. Modules default is define LDO mode in firmware and it have to plus external 32.768khz oscillator for MCU boot and work for.
Once it removed external crystal of 32.768khz, the system would be boot up from internal crystal.
- When not using NFC, please remove NFC Radio Frequency Coil and C235/C236/C237/C238
- Please remove Y1/C7/C9 when using the internal 32.768khz RC oscillator.
- 32MHz crystal oscillator and RF (VDD) DC/DC inductor (Reg1) are built in the module.
- Proposed L5 specifications useing, 0603 chip inductor, IDC, 10 μ H, tolerance recommend minimum 80mA, \pm 20%.

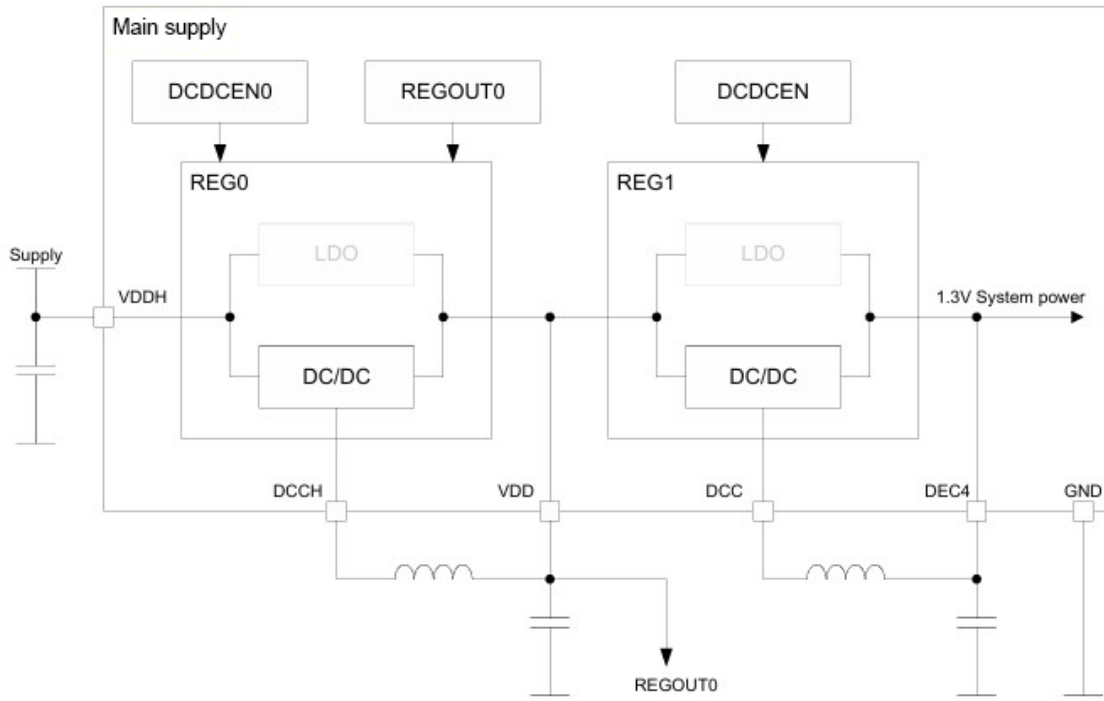

Dexatek Com

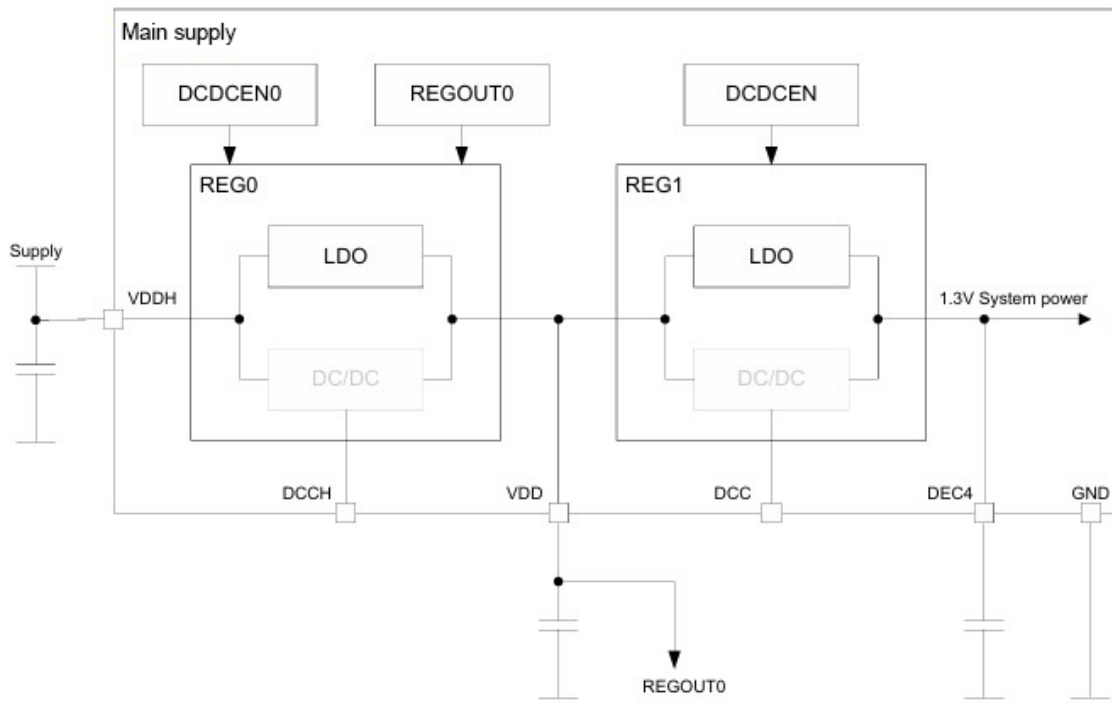

Dexatek Confidential

8.3. Reg0 DC/DC and LDO Mode Disable

Recommend using when the highest input voltage is less than 3.6V.

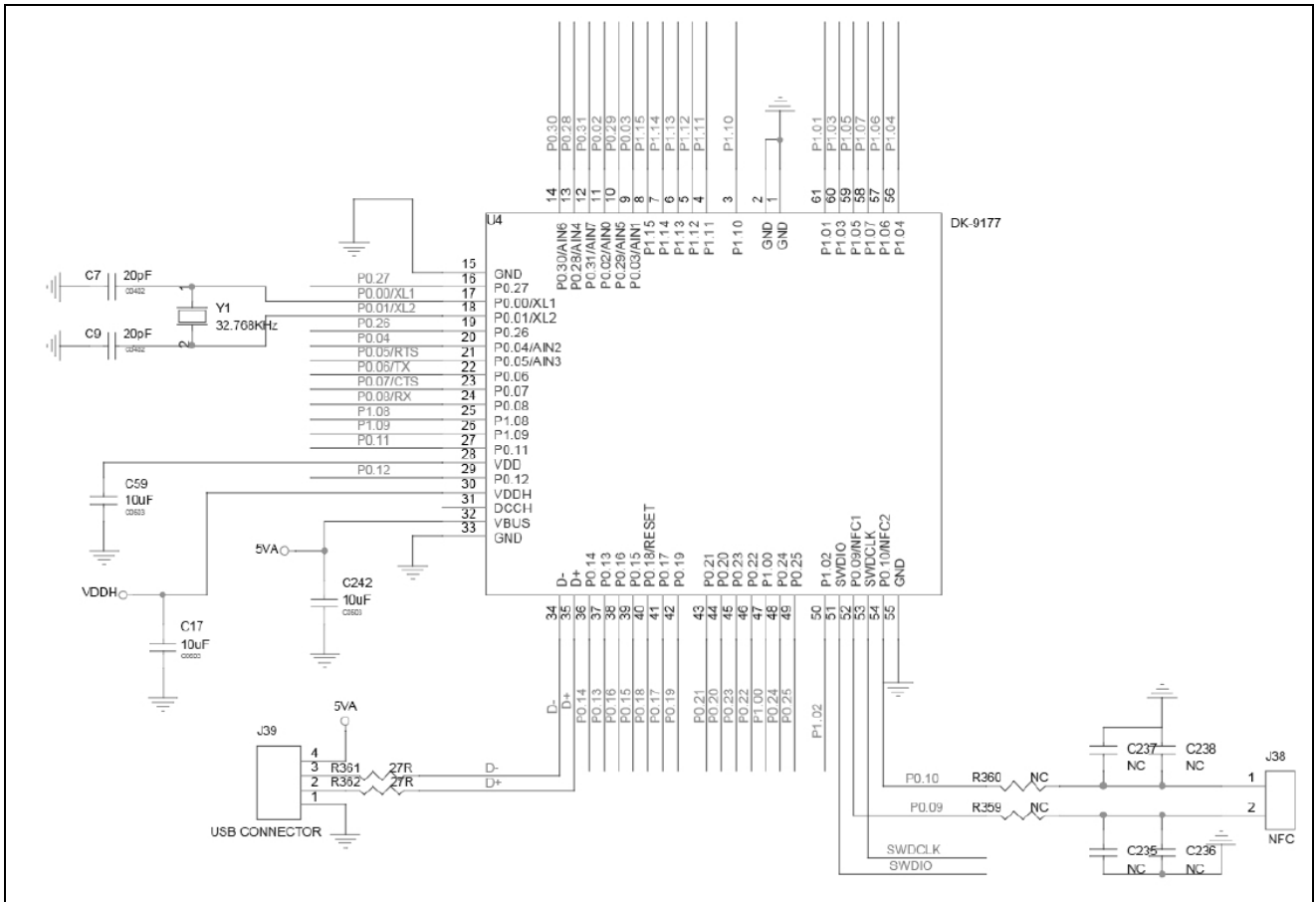

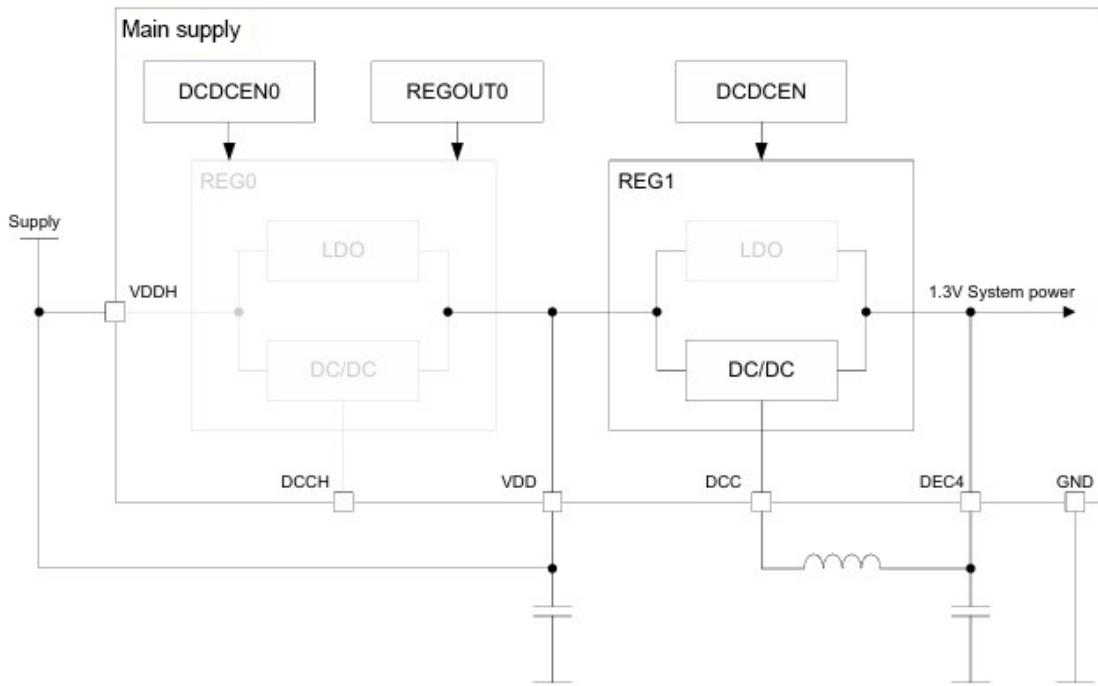
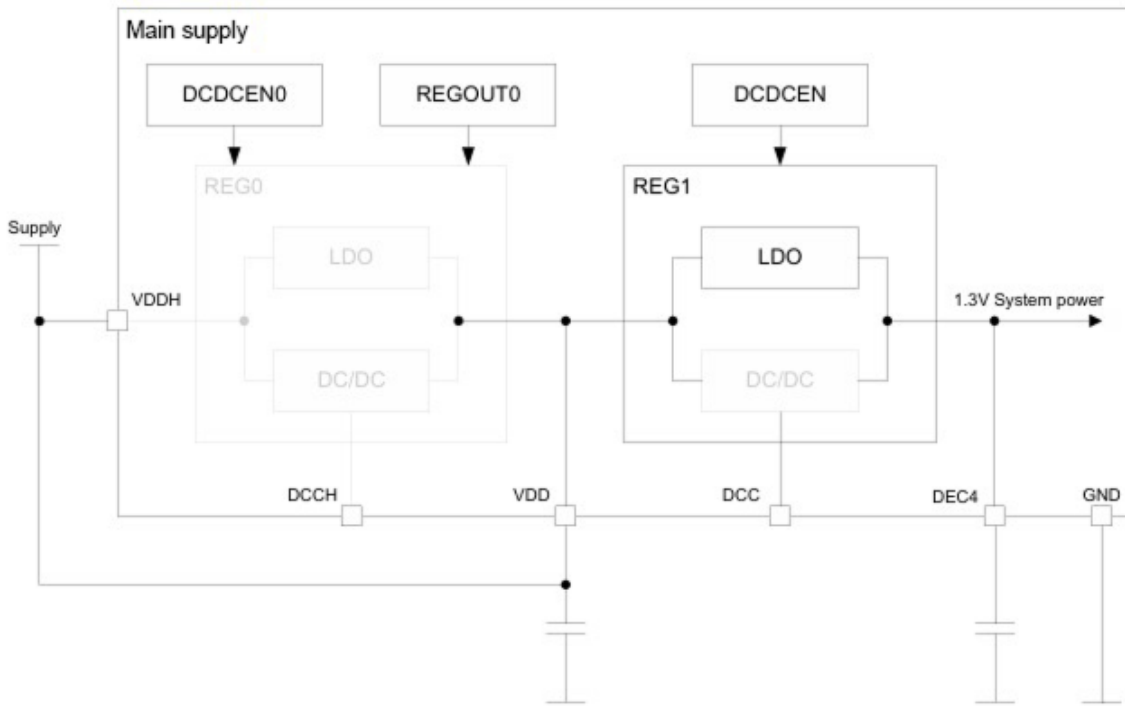

8.4. USB Powered

Recommend using when power the device via USB.

8.4.1. Reg0 DC/DC Enabled

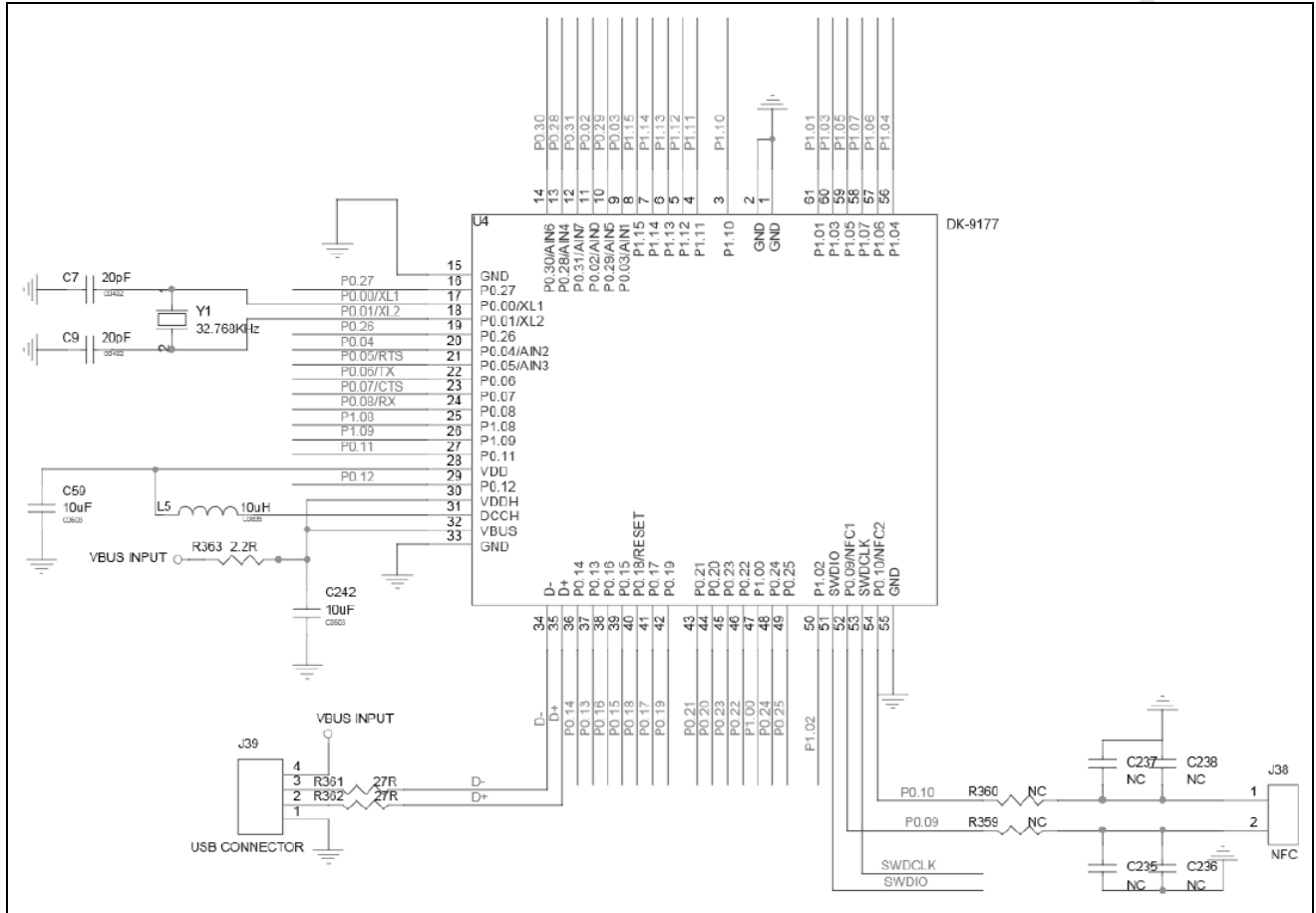

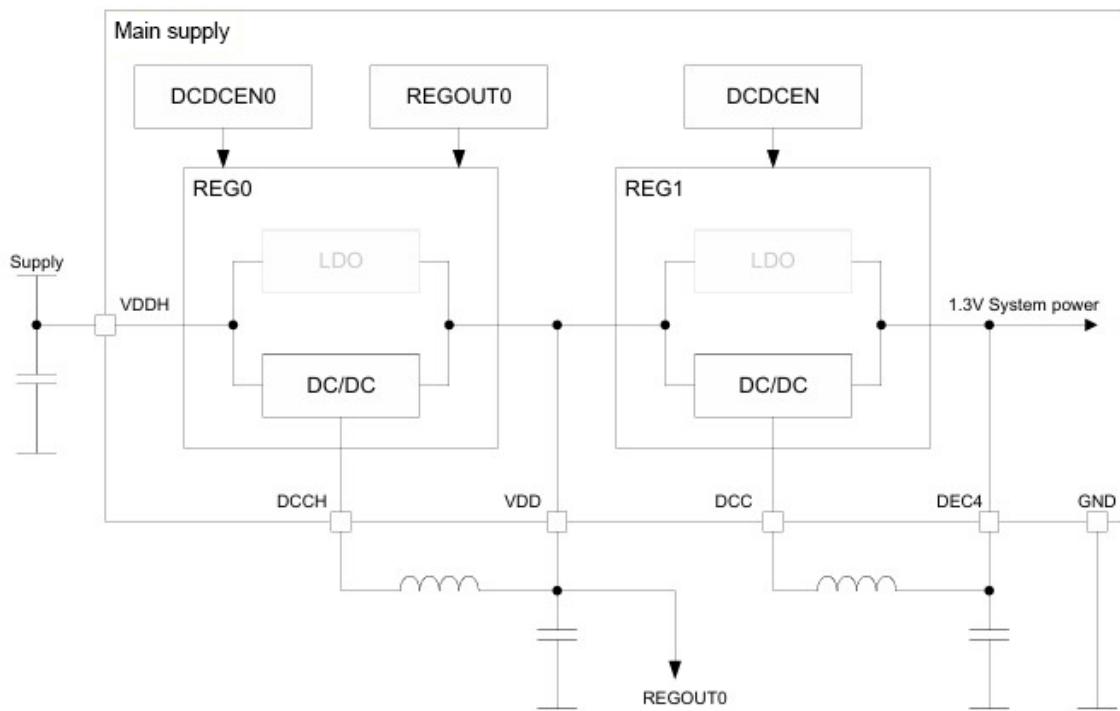

Dexatek Com.

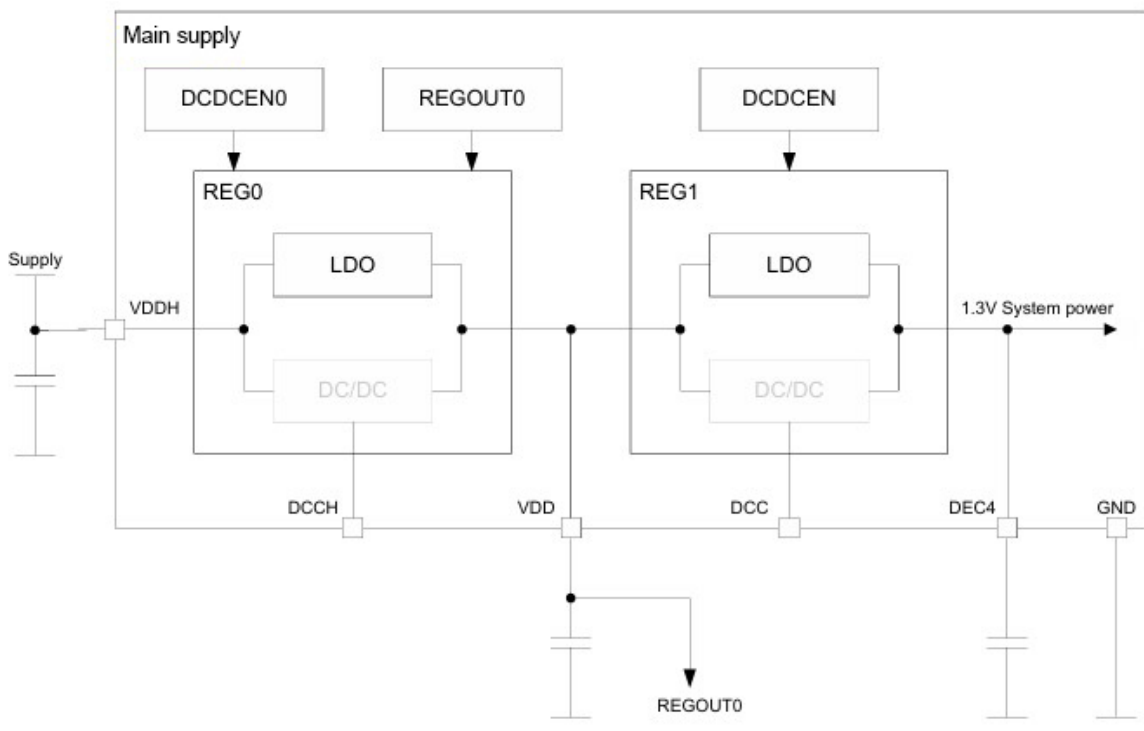

Dexatek Com.

9. Notes and Cautions

1. Follow the conditions written in this specification, especially the control signals of this module.
2. The supply voltage should abide by the maximum ratings and must to supply within range of specification.
4. This module should not be mechanically stressed when installed.
5. Keep this module away from heat. Heat is the major cause of decreasing the life time of these modules.
6. Avoid assembly and use of the target equipment in conditions where the module temperature may exceed the maximum tolerance.
7. Keep this module away from other high frequency circuits.
8. Refer to the recommended pattern when designing a board.
9. Do not expose modules under direct sunlight for long duration. Modules should be kept away from humid and salty air conditions, and any corrosive gasses or substances. Store it within -40°C to $+125^{\circ}\text{C}$ before and after installation.

10. Basic Facts for nRF52 Family

Below chart shows basic spec for Nordic nRF52 family, which is helpful to understand the differences between each SoC. Any discrepancy shall refer to Nordic's technical document as final reference.

Solution	Nordic 52840	Nordic 52833	Nordic 52832	Nordic 52810
Antenna	IpeX		IpeX	
Antenna Vendor	X		X	
RAM (KB)	256KB	128KB	64KB	24KB
Internal Flash	1MB	512KB	512KB	192KB
External flash	X	X	X	X
PIN OUT	48	42	32	32
Shielding Case	O	O	O	O
Package	6x6mm QFN48	7x7mm aQFN™73	6x6mm QFN48	6x6mm QFN48
RF	BT5.3	BT5.3	BT5.3	BT5.3
PA	X	X	X	X
Operating Temp	-40~85C	-40~105C	-40~85C	-40~85C
Tx Power(MAX)	8dBm	8dBm	4dBm	4dBm
Supply Voltage	1.7V~5.5V	1.7V~5.5V	1.7V~3.6V	1.7V~3.6V

11. Useful Links

- Nordic Infocenter: [Nordic Semiconductor Infocenter](#)
- Nordic DevZone: [Nordic Devzone Q&A](#)
- Nordic Document: [Nordic Techdoc](#)
- Nordic Academy : [Nordic DevAcademy](#)
- nRF52840 Product Specification: [Bluetooth 5 SoC - nRF52840 Product Information](#)

Full List of DEXATEK's BLE Modules

Nordic Solution	DEXATEK NO.	Antenna	RAM	Flash Memory
nRF52840	DK9177A	IPEX	256 kB	1 MB
nRF52832	DK9178C	IPEX	64 kB	512 kB
nRF52832	DK9180C	PCB	64 kB	512 kB
nRF52840	DK9181A	PCB	256 kB	1 MB
nRF52832	DK9182C	CHIP	64 kB	512 kB
nRF52840	DK9183A	CHIP	256 kB	1 MB
nRF52833	DK9177B	IPEX	128 kB	512 kB
nRF52810	DK9178D	IPEX	24 kB	192 kB
nRF52810	DK9180D	PCB	24 kB	192 kB
nRF52833	DK9181B	PCB	128 kB	512 kB
nRF52810	DK9182D	CHIP	24 kB	192 kB
nRF52833	DK9183B	CHIP	128 kB	512 kB